

Name: _____		Date: _____	Event: _____
City: _____ State: _____		Track: _____	
Track Conditions: <input type="checkbox"/> Indoor <input type="checkbox"/> Outdoor <input type="checkbox"/> Tight <input type="checkbox"/> Open <input type="checkbox"/> Smooth <input type="checkbox"/> Rough <input type="checkbox"/> Hard Packed <input type="checkbox"/> Loose/Loamy <input type="checkbox"/> Blue Groove <input type="checkbox"/> Dry <input type="checkbox"/> Wet <input type="checkbox"/> Dusty <input type="checkbox"/> Grass <input type="checkbox"/> Astro Turf <input type="checkbox"/> Low Bite <input type="checkbox"/> Med Bite <input type="checkbox"/> High Bite <input type="checkbox"/> Other _____			

Front Suspension

Toe: _____
 Ride Height: _____
 Camber: _____
 Caster: 0° 5° Trail: 2mm 4mm
 Kick Angle: 20° 25° 30°
 Oil: _____
 Piston: _____
 Spring: Standard Low Freq. Color: _____
 Front Pivot: Aluminum Plastic HRC
 Kick Shim: Brass Plastic
 Shock Limiters: _____ Stroke: _____
 Shock Location: _____
 Steering Type: Slide Rack Bell Cranks
 Spindle Ball Stud: Standard Low Mount
 Bumper Steer Spacers: _____
 Ackermann Ball Stud: Standard Low Mount
 Ackermann Spacers: _____
 Camber Link: _____

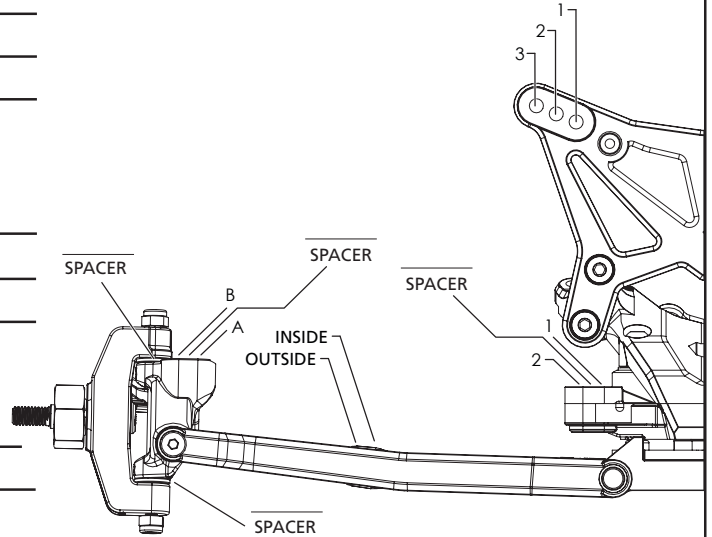

Notes: _____

Rear Suspension

Chassis Configuration: Rear Motor Mid Motor
 Toe: _____
 Anti-Squat: _____
 Roll Center: Low Roll Center (LRC) High Roll Center (HRC)
 Ride Height: _____
 Camber: _____
 Rear Hub Spacing: _____
 Hex Width: _____
 Oil: _____
 Piston: _____
 Spring: Standard Low Freq. Color: _____
 Shock Limiters: _____ Stroke: _____
 Camber Link: _____
 Shock Locations: _____
 Body/Cut Outs: _____
 Battery Position: _____

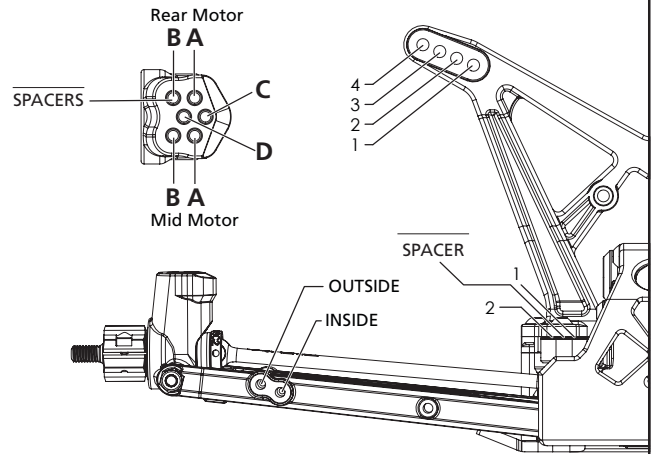

Electronics

Radio: _____	Timing Advance: _____
Servo: _____	Throttle/Brake Expo: _____
ESC: _____	Servo Expo: _____
Initial Brake: _____	Throttle/Brake EPA: _____
Drag Brake: _____	Motor: _____
Throttle Profile: _____	Pinion: _____ Spur: _____
	Battery: _____

Weight Placement
(Mark with "X")

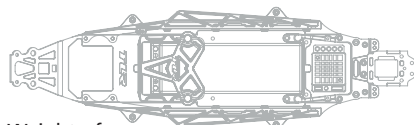

Weight of each piece _____ oz./g

Tires	Tread	Compound	Insert	Additive
Front: _____	_____	_____	_____	_____
Rear: _____	_____	_____	_____	_____
Notes: _____	_____			